

The Standard

COLLECTION

Region: USA - Revision number: 1.1



COOLICON™ THE STANDARD - LARGE 1933™ DESIGN

IMPORTANT:

- For indoor use only
- Shade must be secured between lamp holder and shade rings
- Not intended for use in bathrooms, wet areas or installation in Wiring zones 0, 1 or 2
- All power to the circuit must be switched off at supply source before installation
- Installation to be carried out by a competent professional in accordance with relevant and current building regulations and codes
- Electric cord and connection terminals must be relieved from strain with suitable cord grip and strain relief product
- Ensure luminaire electric cord is 3x18 AWG size and double insulated, see mounting type below
- Always consider the total weight load when installing and suspending your Coolicon™ shade, ensuring sufficient structural support
- Maintain safe distance between luminaire and surfaces

GENERAL INFORMATION:

FINISH:

Vitreous Enamel

MATERIALS:

Gallery & Reflector: Steel

MOUNTING: Suspension type

Non conductive lamp holder fittings, eg. *Plastic*:

Cable 2x18 AWG size

Conductive lamp holder fittings, eg. *Metal*:

Cable 3x18 AWG size



Questions or problems?

Ask the experts
www.bit.ly/3Xx09LY

CARE:

Dust with a dry, soft cloth. Remove greasy or difficult marks with a soft cloth dampened in warm water or glass cleaner, avoiding the badge.

Never use detergents containing abrasives or solvents.

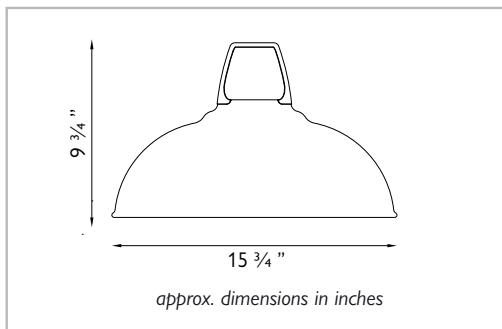

FITTING ORDER:

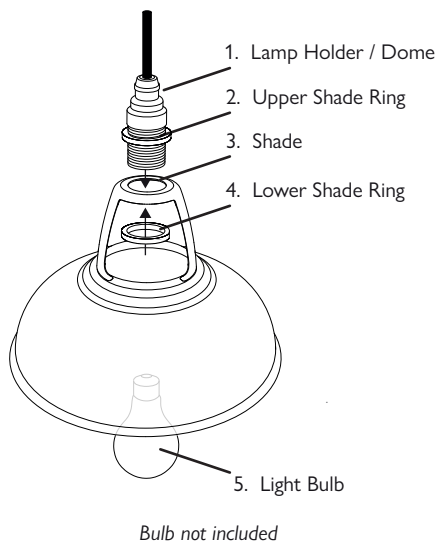

MODEL NUMBER	LIGHT SOURCE	LAMP HOLDER	SHADE WEIGHT	ORIGIN
CL02	All Standard Lightbulbs MAX. GLS. 60W	E26 or E26 UNO with adaptor ring	Aprox. 2.2lb weight may vary due to handmade nature of product	Handmade In England

WWW.COOLICONLIGHTING.COM HELLO@COOLICONLIGHTING.COM





TRADITIONAL VITREOUS ENAMEL

Understanding your Coolicon™ shade

Your shade is finished in Vitreous Enamel, a glass finish that is more durable and vibrant than paint or powder-coat. The traditional process leads to a one-of-a-kind product. In a process largely unchanged in 100 years a glass surface is fused to a steel shade at very high temperatures without using petrochemicals or solvents. Your Vitreous Enamel Coolicon™ shade will last for decades and age beautifully.



Scan here to see our enamel process www.bit.ly/2UfYIH2

Meet Andy, Grandmaster Enameller
Our shades are shaped by people like Andy with decades of skill.



Hallmarks of Vitreous Enamel

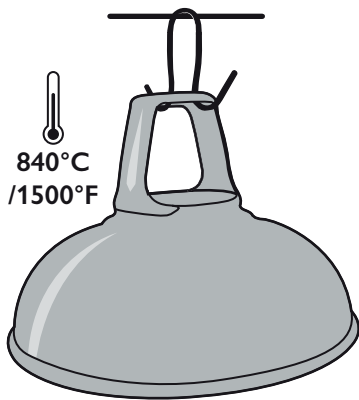

Furnace fired up to 6 times



Hanger Impressions



White Edges



Gallery Wick

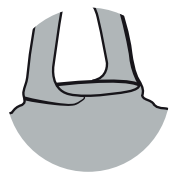

Expressed Edges & Joints



Colour Variation



Freckles



Oxide bumps

- **Impressions:** Small impressions form where the hangers carry the shade through the furnaces.
- **White:** Sometimes a small amount of white enamel wicks around the edge of the shade adding unique character.
- **Wick:** During the multiple firings, continued contact with the hooks can mire the finish around the hole.
- **Edges:** Enamel usually pulls away from edges when the shade is fired. This results in beautiful, dark edges. Sitting proud of the surface, the expressed joint between the gallery and the reflector draws focus to the heritage construction.
- **Colour:** As the molten glass flows over the surface of the red-hot steel the enamel pools and thins, this causes slight variation accentuating the contours of the shade.
- **Freckles:** As we call them at Coolicon™ Lighting, freckles are small dark or light patches in the enamel. Individual to every shade they form in the final firing as the oxides react in the glass to make the final enamel colour.
- **Bumps:** During firing minerals can collect and form bumps, these do not affect the shade's durability.

How to use

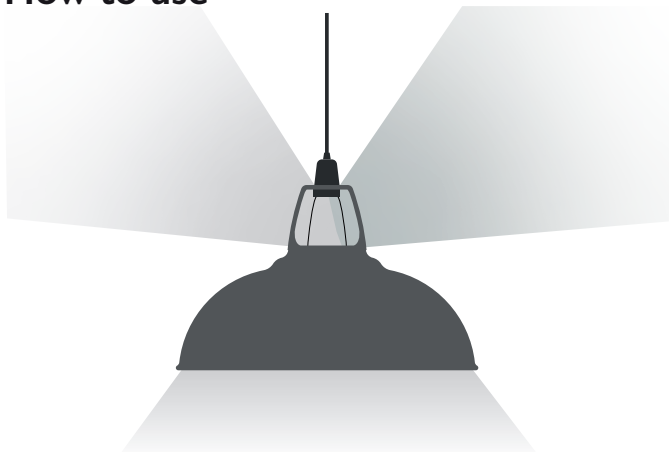

Our roots lie in lighting innovation. Coolicon™ shades specialise in the cooling of light bulbs and balancing of task and ambient light, efficiently lighting above and below.

When the bulb is switched on the light illuminates the top surface of the shade, bringing out the richness and depth of the Vitreous Enamel colour.



Scan here for information on how to use your shade www.cooliconlighting.com/pages/how-to-use